

# 1973-79 Vacuum Hose Kit

## Headlights & Wiper Door

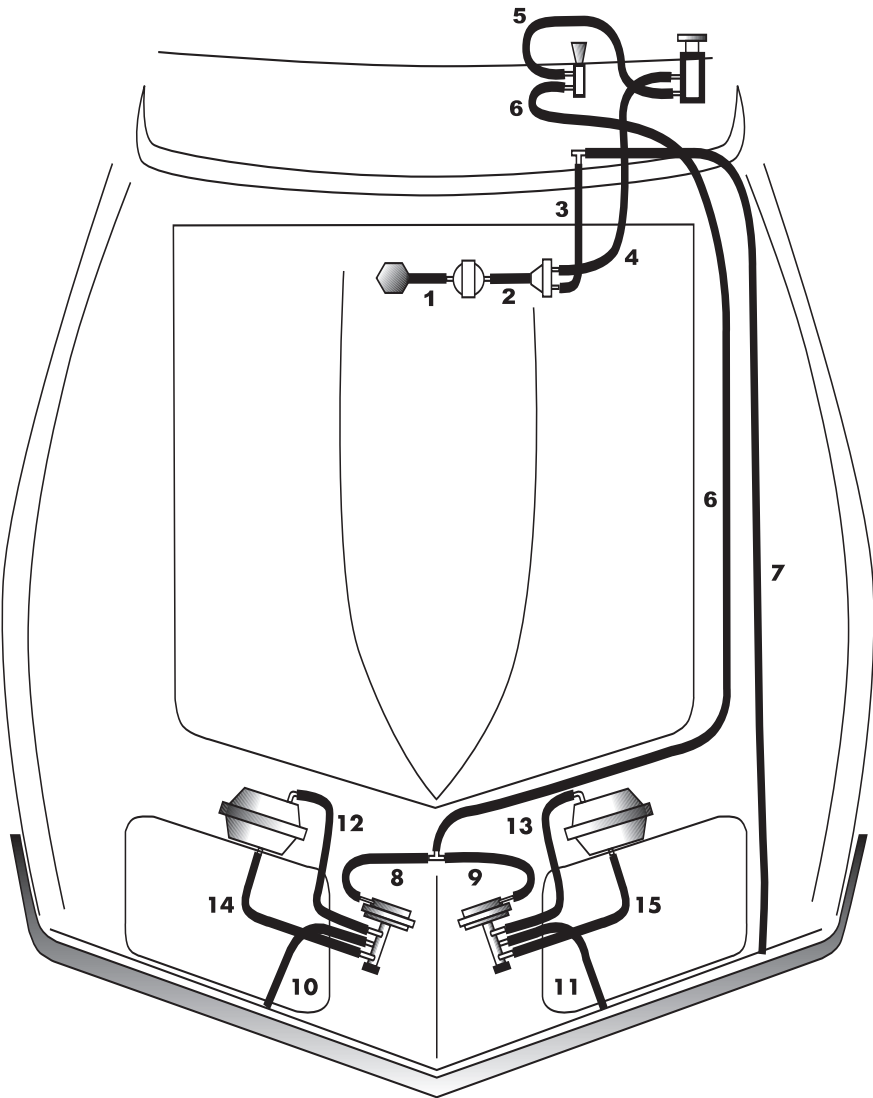

**HE99E**

## INSTRUCTIONS

Hose#				Description
1	Medium	Black	4"	Intake Manifold Fitting To Plastic Filter
2	Medium	Black	6"	Plastic Filter To Metal Valve
3	Medium	Black	15"	Metal Valve To T-Connector (under dash)
4	Small	Black	30"	Metal Valve To Headlight Switch
5	Small	Blue	18"	Headlight Switch To Manual Over-Ride Valve
6	Small	White	100"	Headlight Over-Ride Valve To T-Connection
7	Medium	Black	88"	T-Connector To Vacuum Tank
8	Small	White	6"	T-Connector To RH Headlamp Relay
9	Small	White	6"	T-Connector To LH Headlamp Relay
10	Large	Yellow	12"	Vacuum Tank To RH Headlamp Relay
11	Large	Yellow	12"	Vacuum Tank To LH Headlamp Relay
12	Large	Red	23"	RH Headlamp Relay To Actuator
13	Large	Red	23"	LH Headlamp Relay To Actuator
14	Large	Green	16"	LH Headlamp Relay To Actuator
15	Large	Green	16"	RH Headlamp Relay To Actuator

1. It is best replace hoses one at a time using the diagram and color codes supplied.
2. Hoses 6, 8, & 9 connect to the small T pipe in which the outlets are all the same size.
3. Small T-pipe with different size outlets: Two large outlets connect 3 & 7, small port connects heater/AC vacuum control hose.
4. Hoses 6 & 7 pass through the same firewall grommet.
5. Vacuum lines running together were taped on approximately 6" center. Refer to your old hose harness. New tape is provided in kit
6. Headlight & wiper door actuator relays are color and letter coded  
R = Red, Y = Yellow & G = Green.
7. Two straight connectors are provided for ease of installation under the dash. They install behind the firewall grommet.